

# Instructions and Parts List

## 3M-Matic™

### P/N 78-8069-3924-1 Conveyor Extension Attachment

Type 19000

For Use On:

"3M-Matic"

100a, 200a, 700a, 800a, 800a3, 800ab  
Adjustable Case Sealers  
700r  
Random Case Sealers

### Purpose of Attachment

The Conveyor Extension Attachment when installed on the infeed or discharge end of a case sealer, provides additional conveyor platform surface for non-conveyor operations.

### Specifications

#### Conveyor Extension Attachment Consists of:

Quantity	Description
1	Frame – Conveyor Extension
2	Bracket – Conveyor
8	Washer – Plain, 8 mm
12	Screw – Hex Hd, M8 x 16

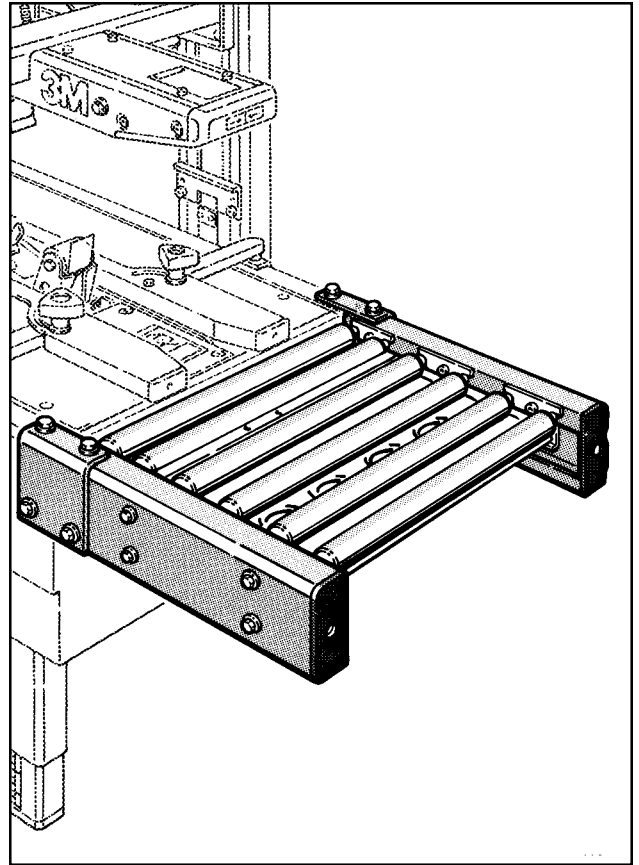

P/N 78-8069-3924-1

#### Conveyor Extension Attachment –

Shown installed on 200a Adjustable Case Sealer

#### Overall Dimensions:

Length – 455 mm [18 inches]  
Height – 130 mm [5 inches]  
Width – 625 mm [24-1/2 inches]

#### Weight:

Packaged – 11.8 kg [26 lbs]  
Unpackaged – 11.3 kg [25 lbs]

## Installation Instructions



**WARNING – Turn "Off" electrical power and disconnect air supply to the machine before beginning installation. Failure to do so could result in injury to personnel or damage to the machine.**

### Conveyor Assembly

1. Remove the conveyor extension and the package of parts from the carton.
2. Verify that the package contains two conveyor brackets, twelve M8 x 16 hex head screws, and eight 8 mm plain washers.
3. To attach the conveyor extension, refer to Figure 1, and locate four screw holes on the end of the case sealer frame.
4. Insert a hex head screw (M8 x 16) in each hole so that only a few threads take hold. **Do not use washers with these screws.**
5. Attach the conveyor extension over the screws using the inverted keyholes in the end of the conveyor. Tighten all four screws with a 13 mm wrench.
6. Refer to Figure 2. Set the conveyor bracket over the joint between the conveyor and the case sealer frame on each side and secure them with four M8 x 16 hex head screws and washers.

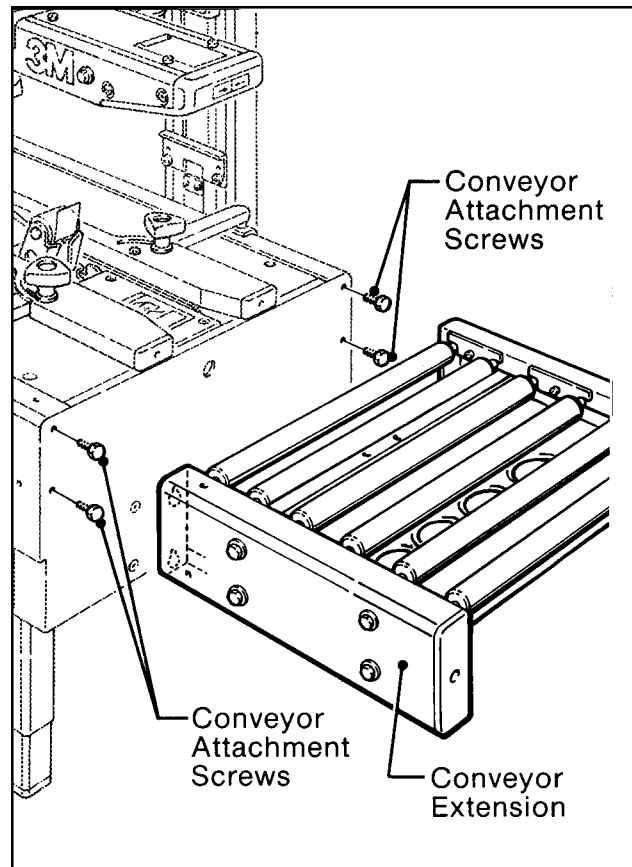

**Figure 1 – Conveyor Extension Installation**

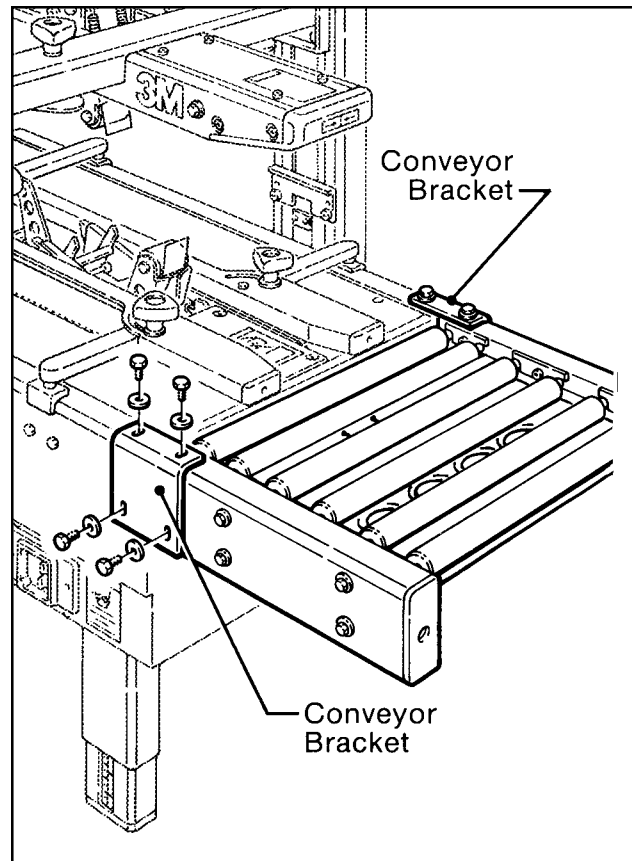

**Figure 2 – Conveyor Bracket Installation**

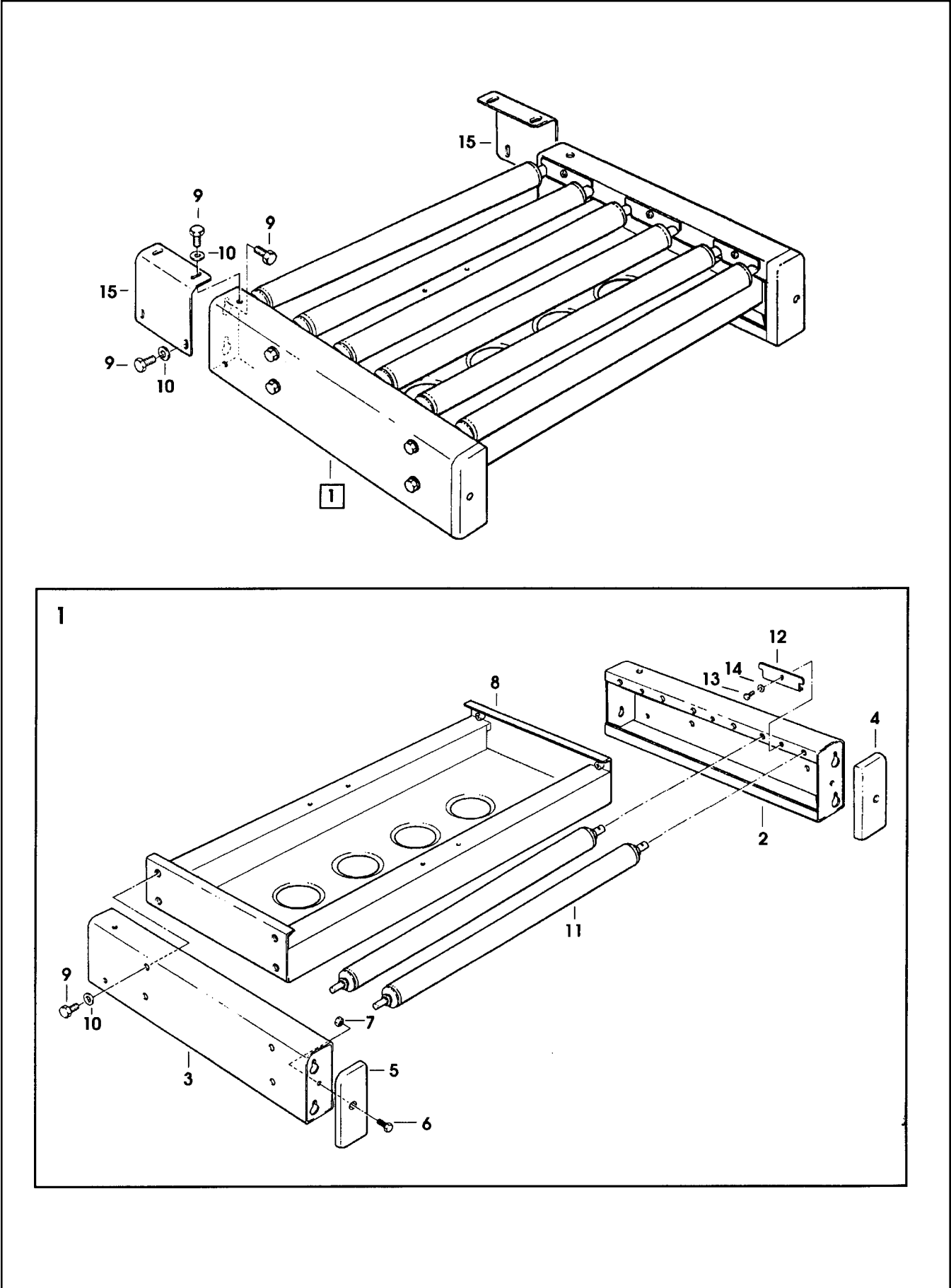

Figure 3 – Parts Illustration (Parts List on Back Page)

# Replacement Parts List

Ref No.	Part Number	Description
1	78-8076-4508-6	Conveyor – Infeed
2	78-8076-4509-4	Frame – R/H
3	78-8076-4510-2	Frame – L/H
4	78-8076-4511-0	Cap – Front, R/H
5	78-8076-4512-8	Cap – Front, L/H
6	78-8032-0375-7	Screw – Hex Hd, M6 x 16
7	78-8010-7418-4	Nut – Hex, M6
8	78-8076-4513-6	Plate – Reinforcement

Ref No.	Part Number	Description
9	26-1003-5841-0	Screw – M8 x 16
10	78-8017-9318-9	Washer – Plain, 8 mm
11	78-8076-4570-7	Roller – 32 x 492
12	78-8076-4507-8	Plate – Infeed
13	78-8010-7157-8	Screw – Hex Hd, M4 x 10
14	78-8005-5740-3	Washer – Plain, 4 mm
15	78-8076-4514-4	Bracket – Conveyor

## How To Order Replacement Parts

1. Refer to parts illustration Figure 3 to find part needed and reference number.
2. Refer to parts list for correct part number.
3. Order by part number, description, attachment part number and name.
4. Replacement parts and part prices available direct from:

### 3M/Tape Dispenser Parts

241 Venture Drive                      800/344 9883  
 Amery, WI 54001-1325                FAX #715/268 8153

Minimum billing on parts orders will be \$25.00 – Replacement part prices available on request.  
 \$10.00 restocking charge per invoice on returned parts.

Note: Outside the U.S. contact the local 3M subsidiary for parts ordering information.

**Equipment Warranty and Limited Remedy: THE FOLLOWING WARRANTY IS MADE IN LIEU OF ALL OTHER WARRANTIES, EXPRESS OR IMPLIED, INCLUDING, BUT NOT LIMITED TO, THE IMPLIED WARRANTY OF MERCHANTABILITY, THE IMPLIED WARRANTY OF FITNESS FOR A PARTICULAR PURPOSE AND ANY IMPLIED WARRANTY ARISING OUT OF A COURSE OF DEALING, A CUSTOM OR USAGE OF TRADE:**

3M warrants that its **3M-Matic™ P/N 78-8069-3924-1 Conveyor Extension Attachment, Type 19000**, will be free from defects for ninety (90) days after delivery. If any part is proved to be defective within the warranty period, then the exclusive remedy and 3M's and seller's sole obligation shall be, at 3M's option, to repair or replace the part, provided the defective part is returned immediately to 3M's factory or an authorized service station designated by 3M. A part will be presumed to have become defective after the warranty period unless the part is received or 3M is notified of the problem no later than five (5) calendar days after the warranty period. If 3M is unable to repair or replace the part within a reasonable time, then 3M, at its option, will replace the equipment or refund the purchase price. 3M shall have no obligation to provide or pay for the labor required to install the repaired or replacement part. 3M shall have no obligation to repair or replace (1) those parts failing due to operator misuse, carelessness, or due to any accidental cause other than equipment failure, or (2) parts failing due to non-lubrication, inadequate cleaning, improper operating environment, improper utilities or operator error.

**Limitation of Liability:** 3M and seller shall not be liable for direct, indirect, special, incidental or consequential damages based upon breach of warranty, breach of contract, negligence, strict liability or any other legal theory.

The foregoing Equipment Warranty and Limited Remedy and Limitation of Liability may be changed only by a written agreement signed by authorized officers of 3M and seller.



### 3M Packaging Systems Division

3M Center, Building 220-8W-01  
 St. Paul, MN 55144-1000

"3M-Matic" is a registered trademark of 3M,  
 St. Paul, Minnesota 55144-1000

Litho U.S.A.

© 3M 2001 34-7004-7484-3(C21.0)